

THE INFORMATION CONTAINED IN THIS DRAWING IS THE SOLE PROPERTY OF GREENFIELD MFG CO ANY REPRODUCTION IN PART OR WHOLE WITHOUT THE WRITTEN PERMISSION OF GREENFIELD MFG CO IS PROHIBITED.

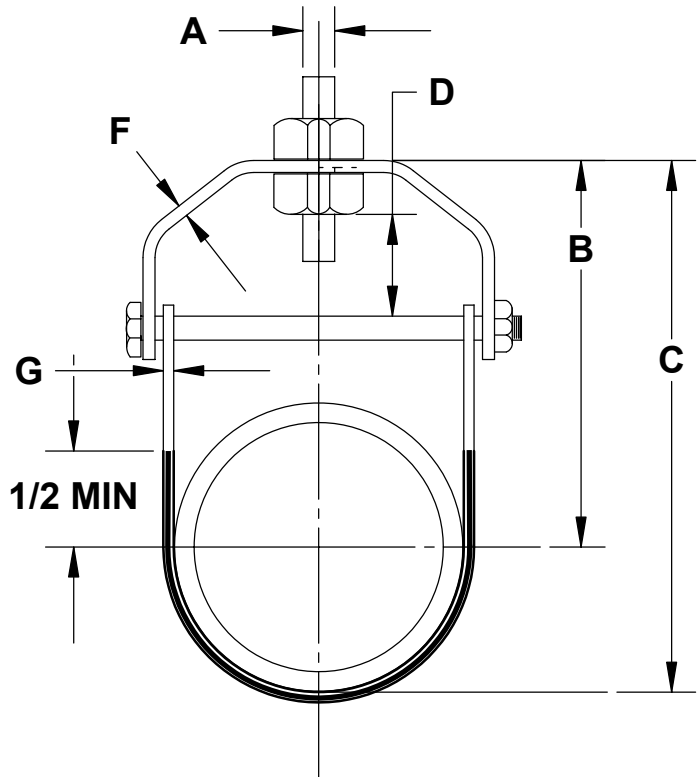

Size	A	B	C	D	E	F-Top	G-Bottom	MAX REC LOAD (LBS)
1/2"	3/8"	1.5	2.0	0.62	1/4"	16ga x .75	18ga x .75	150
3/4"	3/8"	1.8	2.3	0.62	1/4"	16ga x .75	18ga x .75	200
1"	3/8"	2.2	2.8	0.88	1/4"	16ga x 1.0	18ga x 1.0	200
1.25"	3/8"	2.5	3.7	1.20	1/4"	16ga x 1.0	16ga x 1.0	200
1.5"	3/8"	2.8	4.0	1.20	1/4"	16ga x 1.0	16ga x 1.0	200
2"	3/8"	2.8	4.5	1.20	1/4"	14ga x 1.0	16ga x 1.0	250
2.5"	3/8"	3.8	6.0	2.00	1/4"	12ga x 1.0	14ga x 1.0	300
3"	3/8"	4.0	6.5	2.00	1/4"	12ga x 1.0	14ga x 1.0	300
4"	3/8"	4.7	7.0	2.00	5/16"	11ga x 1.25	14ga x 1.25	350
6"	3/4"	7.5	9.5	2.30	1/2"	3ga x 1.50	8ga x 1.50	800
8"	3/4"	8.8	10.5	2.30	9/16"	3ga x 1.75	8ga x 1.75	1500

**Made in USA**

UNLESS OTHERWISE SPECIFIED  
DIMENSIONS ARE IN INCHES

TOLERANCES ARE:  
FRACTIONS    DECIMALS    ANGLES  
+/- 1/8    .XX +/- .03    .XX + 1  
              .XXX +/- .01

MATERIAL  
**STEEL**

DO NOT SCALE DRAWING

CAD GENERATED DRAWING,  
DO NOT MANUALLY UPDATE

APPROVALS	DATE
DRAWN EG	
CHECKED SB	
<b>11/15</b>	

**GREENFIELD MFG CO**  
920 LEVICK ST , PHILA.,PA. 19111

**CLEVIS PLASTIC COATED**

A	P/N	<b>FIG 404</b>	REV.
SCALE	CAD FILE:	SHEET OF	