

THE INFORMATION CONTAINED IN THIS DRAWING IS THE SOLE PROPERTY OF GREENFIELD MFG CO ANY REPRODUCTION IN PART OR WHOLE WITHOUT THE WRITTEN PERMISSION OF GREENFIELD MFG CO IS PROHIBITED.

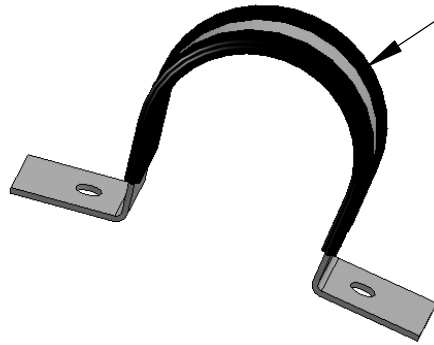

SHAPED TO SNAP ON PIPE

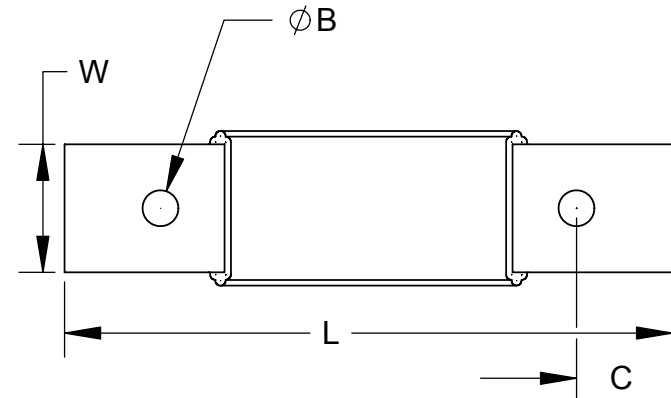
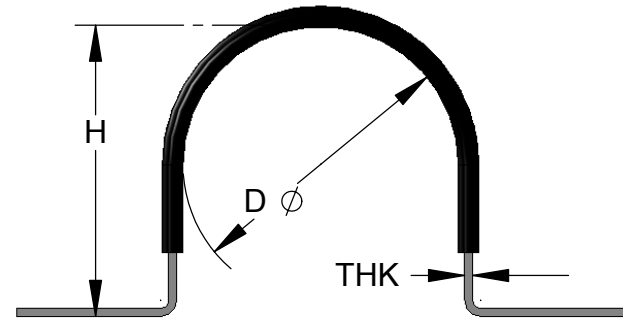

SHOWN AS APPLIED

**EXTRUSION COATING MATERIAL:
SYLVIN 8925-80
HARDNESS 80-90 A DUROMETER
TENSIL STRENGTH 2400
ELOGATION % 375**

SIZE	D	H	Thk	W	L	B	C
+Tol	.06	.03	U S	.12	.25	.032	.06
-Tol	.02	.06	Gage	.03	.12	.015	.03
3/8	.69	.68	20 Ga	.75	2.38	.200	0.38
1/2	.84	.84	20 Ga	.75	2.62	.200	0.38
3/4	1.05	1.05	19 Ga	.75	2.75	.200	0.38
1	1.31	1.31	18 Ga	.75	3.40	.281	0.38
1-1/4	1.66	1.66	16 Ga	1.0	4.25	.281	0.50
1-1/2	1.90	1.90	16 Ga	1.0	4.38	.281	0.50
2	2.38	2.38	16 Ga	1.0	4.75	.281	0.60
3	3.50	3.50	14 Ga	1.0	6.10	.281	0.60
4	4.50	4.50	14 Ga	1.0	7.40	.281	0.60

made in USA

UNLESS OTHERWISE SPECIFIED
DIMENSIONS ARE IN INCHES
TOLERANCES ARE:
FRACTIONS DECIMALS ANGLES
+/- 1/8 .XX +/- .03 .XX + 1
.XXX +/- .01

MATERIAL **PRE GALVANIZED SHEET STEEL**

DO NOT SCALE DRAWING

CAD GENERATED DRAWING,
DO NOT MANUALLY UPDATE

APPROVALS	DATE
DRAWN EG	12/12
CHECKED SB	

GREENFIELD MFG CO

920 LEVICK ST , PHILA.,PA. 19111

P/N **PIPE STRAP, COATED**

A **FIG 603** REV.

SCALE CAD FILE: SHEET OF