

THE INFORMATION CONTAINED IN THIS DRAWING IS THE SOLE PROPERTY OF GREENFIELD MFG CO ANY REPRODUCTION IN PART OR WHOLE WITHOUT THE WRITTEN PERMISSION OF GREENFIELD MFG CO IS PROHIBITED.

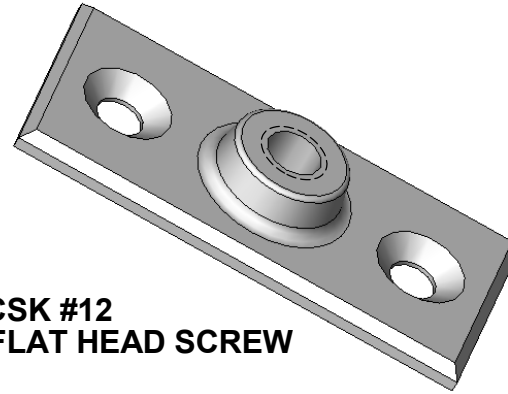
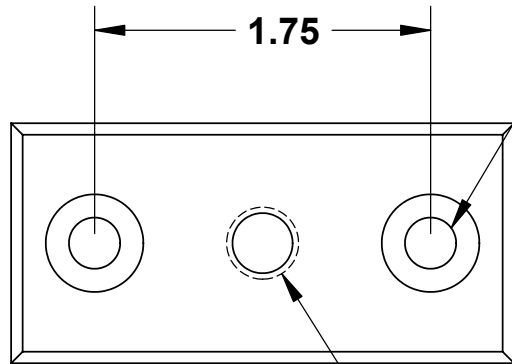
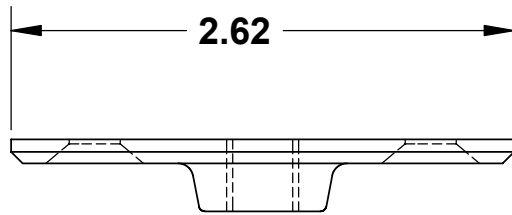

**DRILL & CSK #12
FOR #12 FLAT HEAD SCREW**

**DRILL & TAP
3/8 - 16 UNC- 2B 208-3/8
1/2 - 13 UNC - 2B 208-1/2**

IMPORTED

**MAX REC. LOAD = 180 LBS
FOR 1/2 & 3/8 THREAD**

| | |
|--|---|
| UNLESS OTHERWISE SPECIFIED DIMENSIONS ARE IN INCHES | |
| TOLERANCES ARE: | |
| FRACTIONS +/- 1/8 | DECIMALS .XX +/- .03 .XXX +/- .01 |
| ANGLES .XX + 1 | |
| MATERIAL DUCTILE CAST IRON PLAIN FINISH | |
| DO NOT SCALE DRAWING | |

| | |
|--|-------------|
| CAD GENERATED DRAWING, DO NOT MANUALLY UPDATE | |
| APPROVALS | DATE |
| DRAWN EG | 2/13 |
| CHECKED SB | |
| | |
| | |
| | |

| | |
|-------------------------------------|--|
| GREENFIELD MFG CO | |
| 9800 Bustleton Ave, Phila, PA 19115 | |
| P/N | HANGER FLANGE |
| A | FIG 820 |
| SCALE | CAD FILE: FIG 820.SLDDRW SHEET OF |

REV.